

N°4 estremita' spilate e staginate  
N°4 tinned and stripped ends

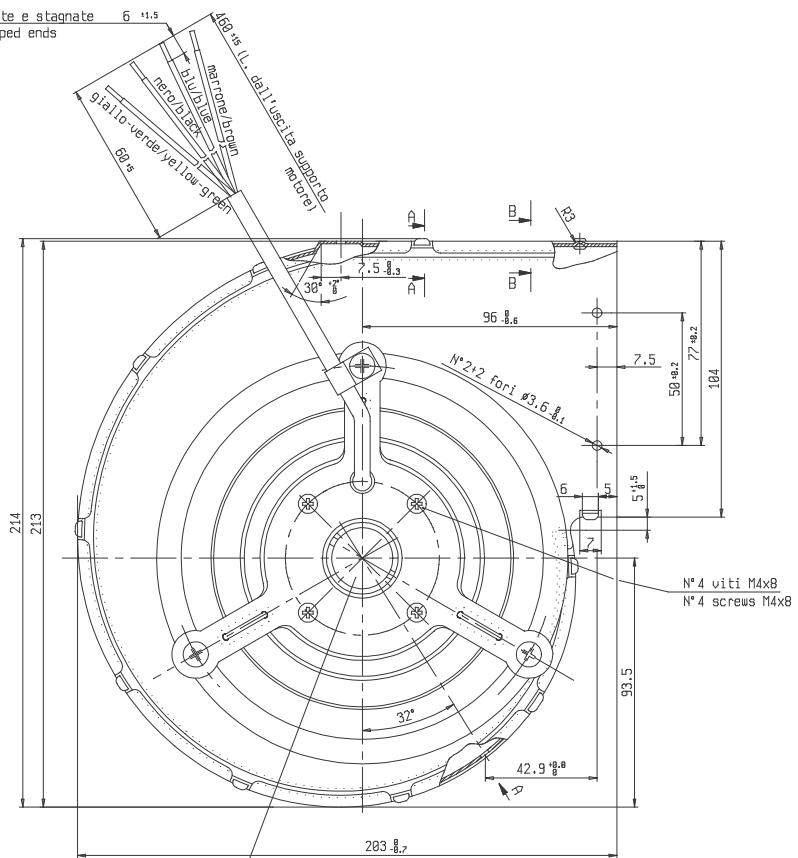

Sezione/Section B-B  
scala/scale 2:1

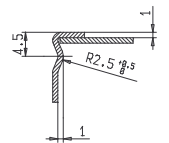

Sezione/Section A-A  
scala/scale 2:1

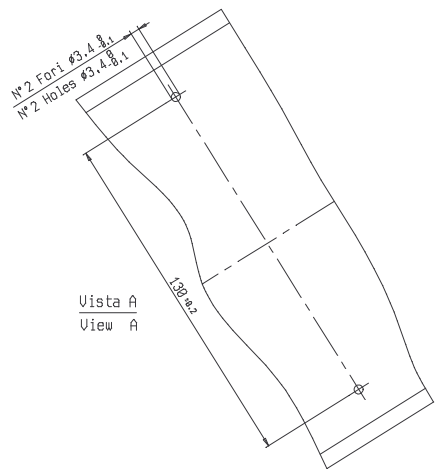
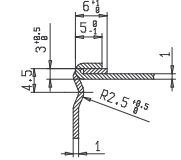

Motor data:  
M25 220V~ 50/60Hz 0.68A 150W 1250min-1 4JF 400V TH  
CL.B 97311

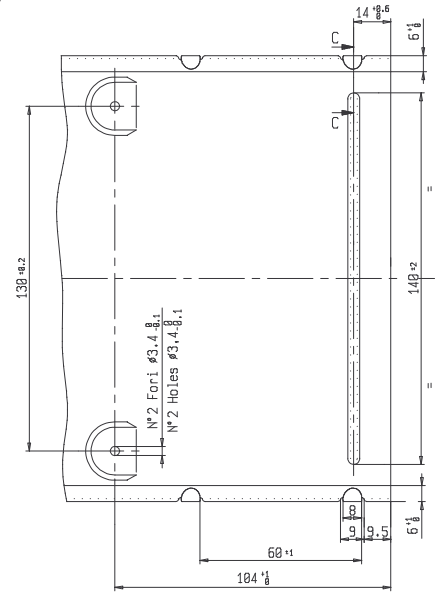

Sezione/Section D-D  
scala/scale 2:1

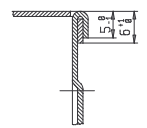

		Complesivo MOTOVENTILATORE M25 2 POLI CL.B FANMOTOR M25 2 Poles CL.B	File TH 30731100
Disegnato Trevisan	Visto .....	Elemento DISEGNO D'INGOMBRO-DIMENSIONAL DRAWING	Dis. 30,97311,00
Data 28.04.05	Scale 1 : 1	Materiale .....	Trattamento .....

MODIFICHE  
 -Rif. Sampling PB738.